

POWER TO LIFT



HIGH LIFTING CAPACITY AND LOW TARE WEIGHT

New mid-range cranes (16-28 tm) with
extra precision and high speed for
your daily lifting tasks





FAST, STRONG AND PRECISE

The new cranes in the mid-range offers the best lift-to-weight ratio within this range. This allows for an optimum utilisation of the crane and the vehicle and thereby an even better business on a daily basis.

The steel quality is ultra-high tensile steel, and all the sub-components are treated either with zinc-nickel or zinc-iron coating. This gives you an optimum corrosion protection of your crane, a perfect finish and a long life span at the same time as all Danish and European environmental standards have been respected.

LOW TARE WEIGHT HIGH LIFTING CAPACITY

A stronger and larger base allows for increased lifting capacity and furthermore the cranes have generally been reinforced and optimised to obtain an excellent lift-to-weight ratio.

The cranes have been designed to offer extra space on the vehicle by having the lowest possible dimensions.

On medium range cranes with 5 to 8 extensions, the suspension traverse is even lower than before, which makes stowing of the crane faster and offers more space on the truck body.



150 L HYDRAULIC TANK ALLOWS FOR MORE SPACE ON THE VEHICLE

The new 150 l tank fitted on the crane offers more space on the chassis of the vehicle and also ensures that you can work with the crane in a fast and efficient way for a longer period of time without the risk of the oil being over-heated.

NEW DIGITAL SLEWING SENSOR OFFERS NEW POSSIBILITIES

The new integrated slewing sensor optimises the reaction from the safety system as the stability area is registered with maximum precision.

POWER STABILIZER NEW STABILIZER SPREAD

The HMF 2310 through HMF 2820 models are available with a new, large stabilizer spread of 7.4 m, which offers increased stability, also on rear-mounted cranes.

SAFETY FIRST



EVS - THE ORIGINAL VEHICLE STABILITY SYSTEM

EVS is a dynamic stability safety system which constantly monitors the stability of the vehicle in all working areas during crane operation. EVS actively incorporates the load on the vehicle, the inclination of the ground, the vehicle heel, the load moment of the crane and its working speed.

EVS increases the working area of the crane by calculating improved stability factors, for instance the load on the truck body and the stabilizer spread.

The system meets the requirements of the EN 12999, which covers safety on loader cranes.

ALTERNATIVE SAFETY WITH AUTOSWITCH

With AutoSwitch you can select the 2CYBEL setting with 2LMB, if you want to switch the EVS off. The EVS system is deactivated when the stabilizer beams are fully extended and the stabilizer legs are on the ground. It is a requirement, however, that during the stability test, the crane fitter has made sure the vehicle is stable with the correct CYBEL support.

HMF INFOCENTRE

The HMF InfoCentre constantly provides information on the current load and operation, so that you can see the load moment, the inclination of the vehicle and a lot more. If the crane stops, you can read the reason immediately, and take suitable precautions.

BEW - BEAM WARNING

New, simplified warning system monitoring whether the stabilizer beam is in correct transport position.







MORE USER-FRIENDLY THAN EVER BEFORE

When upgrading the cranes in the medium range, not only have we taken quality, safety and strength into consideration but also user-friendliness. And therefore, we have developed a number of new features & options that will make your working day with crane operation even more efficient.

NEW AND STRONGER FLY-JIB

- WITH HIGH CAPACITY

The new Fly-Jib 700 is flexible with over-bending to get access under difficult conditions. Strong, optimised match between crane and Fly-Jib for lifting in high positions. Low tare weight that allows for a larger load on the truck body and offers a particularly excellent weight-to-lift ratio on the crane and Fly-Jib.

EVEN BETTER CONTROL

- AND HIGHER SPEED

A PVG 32 control valve optimised to the PCC, PFC and SBC functions in combination with a new high-pressure filter kit provides higher oil flow and thereby lower generation of heat from pump to control valve which ensures higher working speed, low maintenance costs and thereby improved operating economy.



Progressive Crane Control (PCC)

The PCC function dampens both mechanical and hydraulic oscillations during sudden movements with the control valve levers, so crane movements are more flexible, while the work is more efficient and wear and tear is reduced.

Priority Flow Control (PFC)

PFC controls the oil flow when operation requires more oil capacity than the pump can deliver, so none of the crane functions are stopped. All functions run, just more slowly, except for slewing, which is kept constant. This improves the operating economy, while at the same time the fast working pace is still ensured.

Slew Braking Control (SBC)

SBC dampens the slewing movement in case of sudden stops, and provides smooth slewing movements, comfort and efficiency in case of intensive use and high oil flow. Fast work (typically loading and unloading with a grab at a long distance) can be carried out faster. The impact and wear on the crane components are reduced and you obtain a higher re-sale value.

HIGH-PRESSURE FILTER KIT WITH HIGHER OIL FLOW

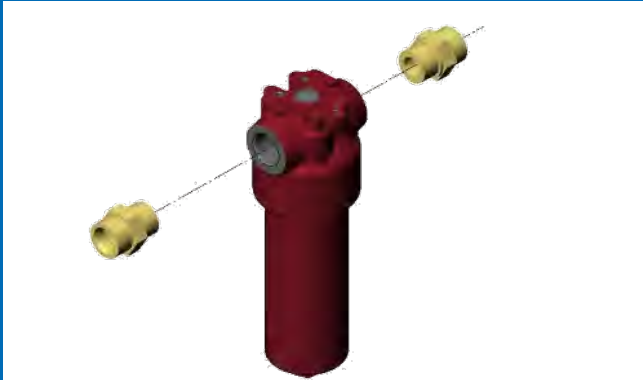

Allows for higher oil flow and thereby higher working speed. Furthermore it provides low generation of heat with variable flow pump, which extends the life span of the oil.

POWER PERFORM - NEW PVG CONTROL VALVE

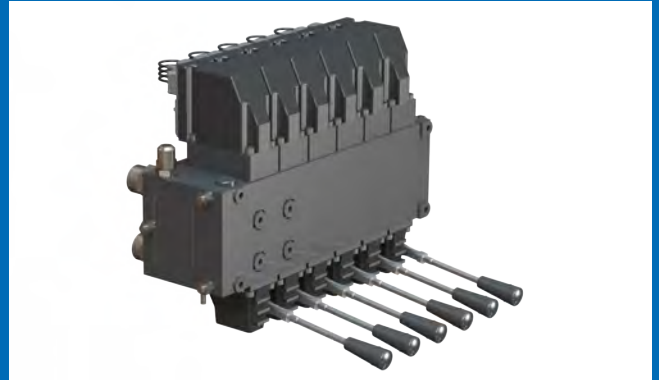

New PVG 32 control valve adapted to the SBC, PCC and PFC functions. Provides higher oil flow and thereby faster reaction and an even higher precision on the boom and jib cylinders.

MAIN BOOM WITH INCREASED STRENGTH



New and improved design of the main boom optimises strength and lifting capacity and provides more resistance to wear.

EXTENSION PROFILE WITH EXTRA STRENGTH



A wide hexagonal profile with large bearing surfaces combined with ultra-high tensile steel gives extra great strength and precision, both in case of vertical and horizontal lifting tasks.

HMF MEWP PERSONNEL BASKET

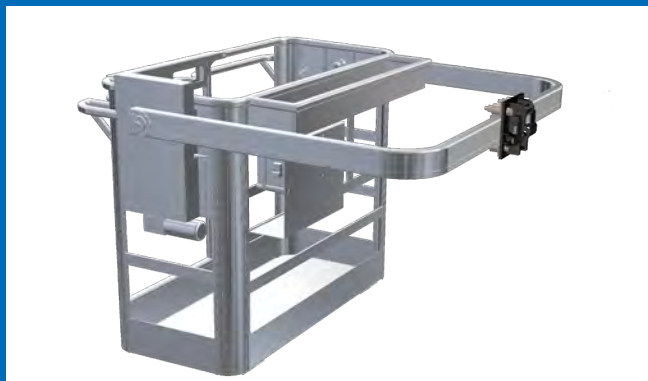

HMF MEWP with long reach offers the possibility of more and new lines of business as it is easy to change between tasks with personnel lifting and traditional crane operation.

HMF OIL COOLER WITH INCREASED COOLING EFFECT



. HMF oil cooler with thermostat and "soft start" ventilator.

MANY COMPONENTS IN ZN-NI OR ZN-FE

EXTENSION PROFILE WITH EXTRA STRENGTH

MAIN BOOM WITH INCREASED STRENGTH

EVS OR 2CYBEL

STABILIZER BEAM WITH EXTRA WIDTH



HMF - POWER TO LIFT

LIFTING CAPACITY

1620K-RCS

1620K1-RCS

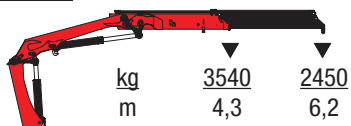

1620K2-RCS

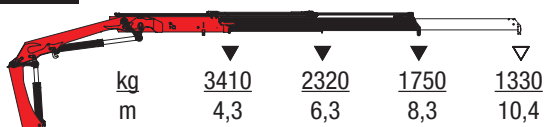

1620K3-RCS

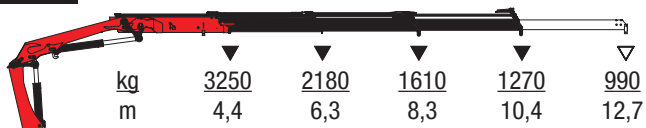

1620K4-RCS

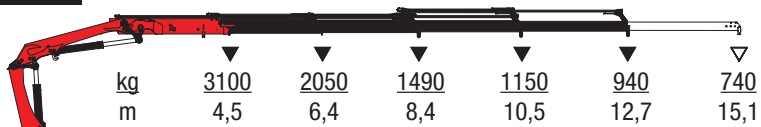

1620K5-RCS

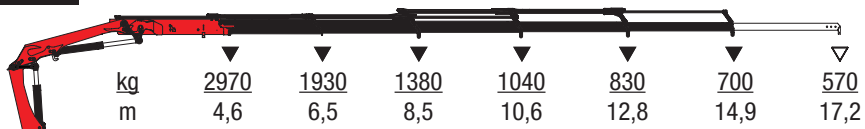

1620K6-RCS

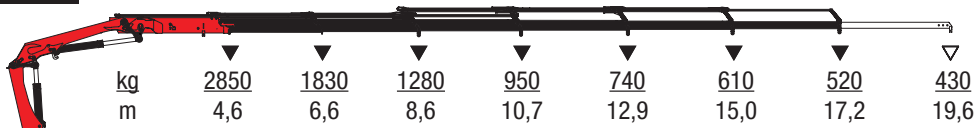

▽ Lifting capacity with manual extensions

▼ Lifting capacity, no manual extensions

DIMENSION SKETCHES

1620K-RCS

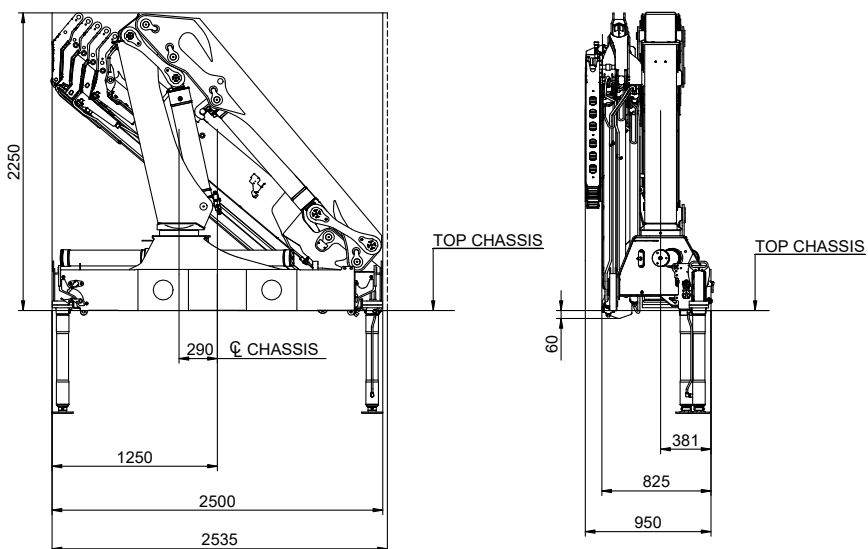
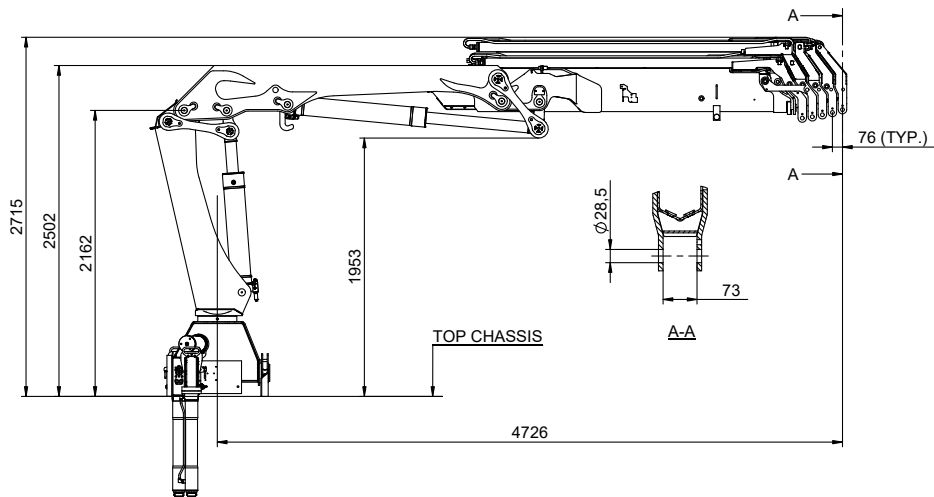

DATA SHEET

TECHNICAL DATA	1610K3-RCS	1620K3-RCS	1910K4-RCS	1920K4-RCS	2310K5-RCS	2320K5-RCS	2810K5-RCS	2820K5-RCS
MAX. LOAD MOMENT, TM	14.3	14.3	16.8	16.8	19.2	19.4	24.2	24.3
MAX. HYDRAULIC REACH, M	10.5	10.5	12.8	12.8	14.8	14.8	14.8	14.8
MAX. HYDRAULIC REACH WITH FLY-JIB, M	N/A	N/A	N/A	N/A	N/A	N/A	N/A	25.2
SLEWING TORQUE, KGM	1795	1795	1795	1795	2765	2765	2765	2765
SLEWING AREA	400	400	400	400	400	400	400	400
WORKING PRESSURE, BAR	365	365	365	365	365	365	365	365
WEIGHT CRANE, KG	1590	1640	1785	1835	2250	2350	2415	2500
BEAM EXTENSION, WIDTH, M	4.6 - 6.4	4.6 - 6.4	4.6 - 6.4	4.6 - 6.4	5.5 - 7.4	5.5 - 7.4	5.5 - 7.4	5.5 - 7.4
MAX. PUMP PERFORMANCE, L/MIN	70-100	70-100	70-100	70-100	70-100	70-100	70-120	70-120
MAX. POWER CONSUMPTION, KW	43-61	43-61	43-61	43-61	43-61	43-61	43-73	43-73
FOLDED WIDTH, MM	2500	2500	2500	2500	2500	2500	2500	2500
WEIGHT OF STABILIZERS	200 - 315	200 - 315	200 - 315	200 - 315	290 - 365	290 - 365	290 - 365	290 -365
LENGTH OF CRANE	825	825	825	825	885	885	885	885

