

HMF 250-T



- power to lift.

HMF T-Boom Range Loader 250-T

Small and light – long and strong

- Tare weight only 240 kg
- Large efficient slewing area
- Lifts 600 kg at 3.2 metres
- Easy and simple electro-hydraulic operation
- Built-in safety: load-holding valves on all cylinders
- 360° swing-up stabilizer leg
- Fast and easy mounting
- Also available with space saving M-base

Loading group B2		250-T2
Load moment	tm	2.0
Hydraulic reach	m	3.2
Slewing torque	kgm	190
Slewing angle	°	365
Height above chassis	mm	1680
Weight incl. 1 stabilizer and power pack	kg	240
Working pressure	MPa	18.0
Pump performance	l/min	6-8
Oil tank capacity in base	l	6.5
Separate electro-hydraulic pump	V	12/24
Power consumption	V	12
	amp	280
Power consumption	V	24
	amp	140

HMF 250-T2

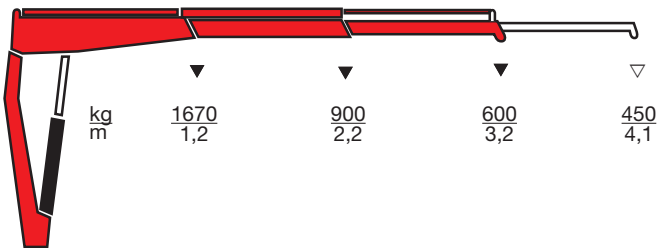
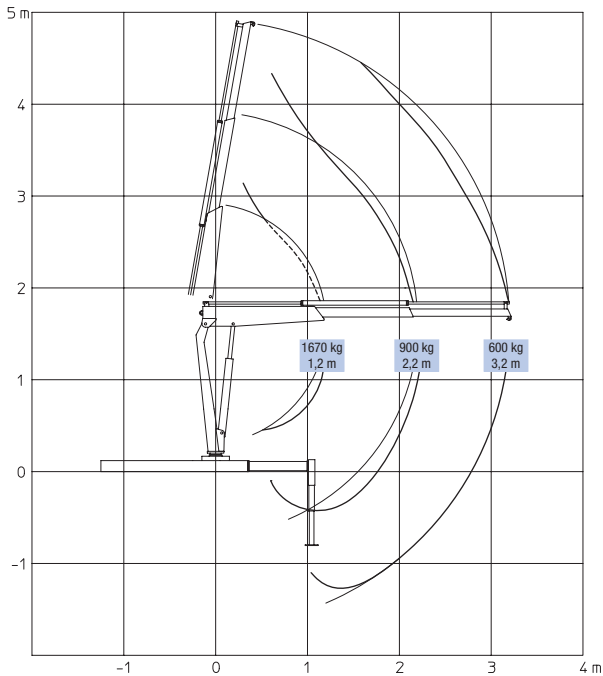

▼ Lifting capacity without manual extensions

▽ Lifting capacity with manual extensions

Z008055-2

We reserve the right to introduce improvements and modifications

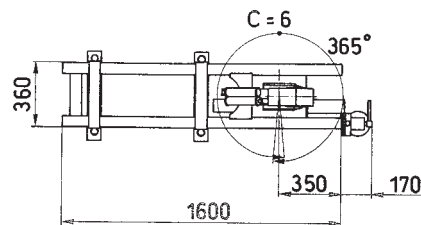
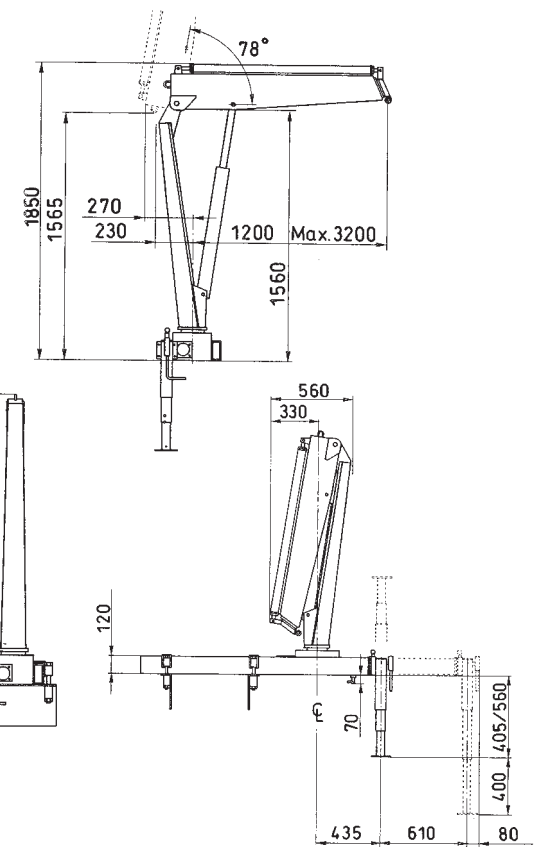

Standard base

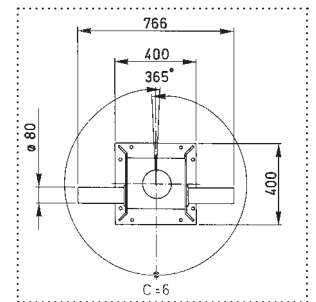

M-base



Højbjerg Maskinfabrik A/S • Oddervej 200 • DK-8270 Højbjerg
Tel.: +45 8627 0800 • Fax: +45 8627 0744 • info@hmf.dk

www.hmf.dk